



- The fast "Spot-on" synchroniser
- LEAD and/or LAG synchronising facility
- Breaker closing time compensation
- Dead-bus facility
- "Easy view" status presentation
- Generator speed control (relays)
- Generator speed reference (analogue output)
- System status output

Specifications

Monitored Voltage	25-500VAC, 40-70Hz
Input:	
Aux. Supply:	AC: 100-120, 200-240, 380-415, or 440-460VAC, 40-70Hz (Fuse 0,5A) DC: 24 or 36-160V (Fuse 2A)
Voltage Tolerance:	± 10%
Contact Rating:	AC: 100VA - 250V/2A max. DC: 50W - 100V/1A max.
Adjustments:	
Frequency diff:	0,1-2Hz
CB closing time:	30-300mS
High voltage:	2-15% of net voltage
Low voltage:	2-15% of net voltage
Pulse rate:	12-60 pr min
Pulse width:	120mS to 1,6secs
*Analogue output:	-10/0/+10mADC = -5/0/+5Hz max 400ohm
*Optional output:	-3/0/+3VDC (-3/0/+3Hz) min 50kohm <i>*Only active when Sync. mode is selected</i>
Temperature:	-20 to +70°C
Weight:	0.7kgs
Front protection:	IP21

Unit meets IEC60092-504 and relevant environmental and EMC tests specified in IEC60068/60092 and IEC61000/60533 respectively, to comply with Classification Societies requirements.

Megacon is the inventor of the original, now industry standard "rotating" LED display, and a trendsetter in modern synchronisation control.

Description

The digitally controlled KCQ104EJD42 provides both visual presentation of voltage differential and relative speed and phase angle relationship and speed control output signals necessary to achieve fast automatic "Spot-on" synchronising between two systems. When used as dead-bus coupler the CB close relay will energise when bus is "dead" and the digital input (dead-bus enable) is closed (mode 4 to 6, see page 2).

Its many important features contribute to make KCQ104EJD42 simply the best choice available for synchronising in any automatic generator control system (PM-system).

KCQ104EJD42 comes with separate auxiliary supply on terminal 19 & 20.

Applications

KCQ104EJD42 is used for both single and three phase systems. Any two phases (or phase-neutral) can be used for synchronising as long as they are the same two phases on both sides of the breaker. The synchroniser is rated for continuous operation and can be left connected when not in use.

Synchronising modes

To adapt the functionality of KCQ104EJD42 to any specific application, the direction of approach to synchronising (LEAD, LAG or NEUTRAL) can be selected as required:

- LEAD (incomer faster than bus)
- LAG (incomer slower than bus)
- NEUTRAL (will synchronise in both directions)

LEAD is generally the preferred mode. The synchronising relay will then operate when the frequency of the incomer is slightly HIGHER than the bus frequency. This is to avoid motoring of the incomer (entering reverse power condition) after the breaker is closed.

Speed control

The raise/lower relays pulses the fuel control governor motor, or an interfacing MXR845x electronic potentiometer. Pulse length and rate of the speed control relays are adjusted on the rear of the unit to suit the dynamic response of any engine regulator. The speed control has a P/I (proportional/integral) characteristic, with a dynamically controlled dead zone.

Alternatively the linear analogue -10/0/+10mA output signal can be used as speed reference to a generator controller, with polarity and amplitude proportional to frequency difference between the two systems when synchronising mode is selected.

System status:

KCQ104EJD42 is fitted with a system status relay. When power is ok and unit is working correctly the relay activates. It will release on alarm or when unit is not powered.

Normal operation	: Closed contact
Alarm condition/unpowered	: Open contact

Connection

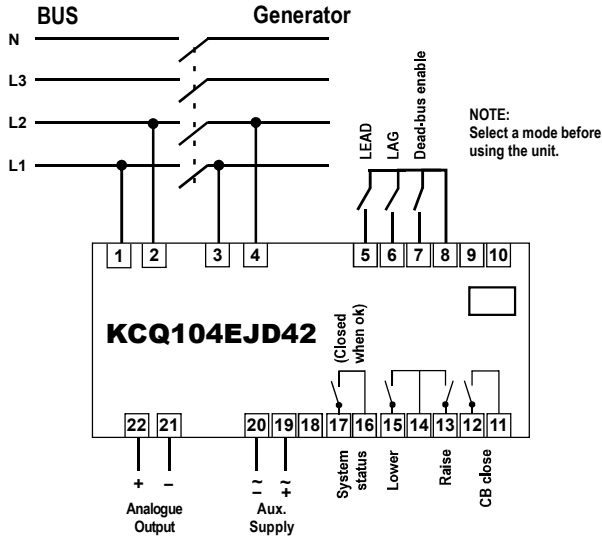

Operation Modes

Mode 1	LEAD	
Mode 2	LAG	
Mode 3	NEUTRAL	
Mode 4	LEAD + DEAD BUS	
Mode 5	LAG + DEAD BUS	
Mode 6	NEUTRAL + DEAD BUS	

Description

“SPOT ON” synchronisation - CB closing time compensation

The dynamically controlled CB closing time compensation provides a **SMOOTH** synchronising, avoiding that the engine/generator couplings are exposed to excessive torque forces. In **FAST** synchronisation the priority, an accurate “SPOT-ON” synchronising will still be maintained even with a high frequency difference between the power sources.

The System “P” synchronising principle

The relay closure is initiated at “T” when the breaker coil is energised and finalises at “P”, assuring a precise “12 o'clock” synchronisation (figs 1 and 2). Allowed frequency difference is adjustable between 0.1Hz to 2Hz.

Typical setting for **smooth synchronising** is 0,2Hz. The angle “a” varies according to the calculated frequency difference between the two systems. The synchroniser operation and accuracy is not influenced by distorted voltage waveform or harmonics.

Synchronisation

Green lamps indicate voltage presence on reference source (BUS PWR, only when generator is powered) and incoming generator (GEN PWR). Green lamps also indicate that voltage and frequency differential between the two systems are within the limits. The synchronising relay will close when above conditions are achieved.

A green lamp (CB close) indicates the closing command to the breaker. Frequency difference and voltage limits, circuit breaker closing time, speed control relays pulse length/rate and synchronising mode are user settable on unit rear.

Note: The CB Close LED will flash when unit is ready for synchronising, but inhibit input is open or synchronising mode is not selected.

System “P”

“Spot-on” synchronising LEAD direction

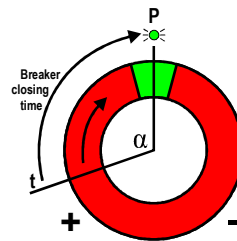

Fig.1

System “P”

“Spot-on” synchronising LAG direction

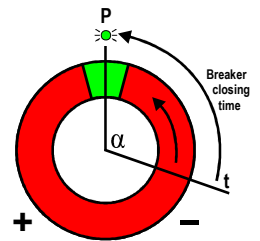
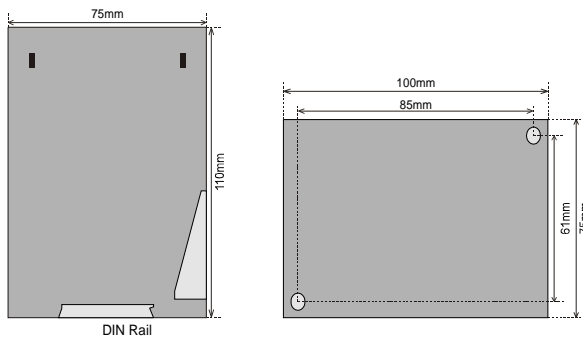

Fig.2

Dimensions



Operation Dead-Bus

Gen.	Bus	Dead-Bus Enable	Operation
Dead	Live	Closed	No CB close
Live	Dead	Closed	CB Close
Dead	Dead	Closed	No CB close
Live	Live	N/A	Normal Synch.

The MEGACON policy is one of continuous improvement, consequently equipment supplied may vary in detail from this publication.

ORDERING INFORMATION

Product type : KCQ104EJD42
 Auxiliary supply : 24VDC
 Network voltage : 380VAC

