



- Under and Over Voltage and Frequency Protection
- Adjustable Voltage and Frequency Deviation Set points
- The Pathfinder function eases fault finding
- Up to two individual very fast analogue output signals (<50mS), (optional)
- DIN96 Slave Indicator with Hz scale (optional)

Specifications

Monitored Voltage:	100-120V, 200-240V, 380-415V, 440-460V, 480VAC 40-70Hz (Fuse 0,5A)
Optional Separate Auxiliary Voltage AC:	100-120V, 200-240V, 380-415V, 440-460V, 480VAC 40-70Hz (Fuse 0,5A)
Optional Separate Auxiliary Voltage DC:	24-60VDC (Fuse 0,5A)
Supply tolerance:	110-220VDC (Fuse 1A)
Power rating:	+10%, -20%
Current Input:	5VA
Contact rating:	1A CT or 5A CT, <0,1VA
Adjustments:	AC: 100VA -250V/2A max. DC: 50W -100V/1A max. Depending on the selected model (See table on the right)
Frequency range:	45-55Hz
(Other range on request)	55-65Hz 45-65Hz 30-70Hz
Analogue output 1:	mA: Up to 20mA, max 500R
(see page 2 for available outputs)	V: Up to 10V, min 100kohm (other on request)
Analogue output 2:	mA: Up to 20mA, max 500R
(see page 2 for available outputs)	V: Up to 10V, min 500ohm (other on request)
Accuracy:	Class 0,5
Temperature:	-20 to +70°C
Humidity, relative:	0-95%
Weight:	0.6kgs
Front protection:	IP21
Flammability:	UL94-V0

The unit meets EN 60255-27 Cat. III, Pollution degree 2 and the relevant environmental and EMC tests specified in EN 60255-26 to comply with the requirements of the major Classification Societies.

Related information:  
The KCFV53x series are also available for panel mounting as KPFV53x series.

Description

The digitally controlled KCFV53x is for use on three phase, three wire systems. KCFV53x provides precision monitoring of frequency and line voltage on any generator system. When trip delays are set to zero (0,1sec) operation corresponds with G59 requirements.

User settable trip levels and delays. LEDs flash during count-down. Colour of LEDs indicates alarm status.

The Pathfinder (only on latching models) indicates the phase (s) causing the trip by the flashing pattern of the relevant LED.

Up to two individual very fast analogue output signals (optional) proportional to Hz range (see page 2 for available outputs). The analogue output is isolated from both voltage input and auxiliary power.

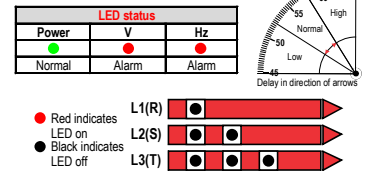

Relay Configurations

Less than 50mS fault detection. R1 (Under & Over Frequency) and R2 (Under & Over Voltage) activates when set level is exceeded and time delay has elapsed. R3 activates when R1 or R2 is activated and can be used as a common alarm.

KCFV53E - KCFV53FA - KCFV53FB

Models	Latch	Output 1	Output 2	Relay	V	Hz	Fail Safe	Latch	Adjustments	Trip level	Delay
KCFV53E	X	-	-	R1		X		X	UV:	0-20% of V nom.	0,1-30secs
KCFV53FA	X	X	-	R2	X		X	X	O/V:	0-20% of V nom.	0,1-30secs
KCFV53FB	X	X	X	R3	X	X		X	U/Hz:	45-65Hz	0,1-30secs
									O/Hz:	45-65Hz	0,1-30secs

(KCFV53E is the standard version)

Relays shown de-energised.  
R2 is fail-safe and energises when unit is powered.

KCFV53C - KCFV53CFA - KCFV53CFB

Models	Latch	Output 1	Output 2	Relay	V	Hz	Fail Safe	Latch	Adjustments	Trip level	Delay
KCFV53C	X	-	-	R1		X		X	UV:	0-20% of V nom.	0,1-30secs
KCFV53CFA	X	X	-	R2	X		X	X	O/V:	0-20% of V nom.	0,1-30secs
KCFV53CFB	X	X	X	R3	X	X		X	U/Hz:	45-65Hz	0,1-30secs
									O/Hz:	45-65Hz	0,1-30secs

Relays shown de-energised.  
R2 is fail-safe and energises when unit is powered.

KCFV53D - KCFV53DFA - KCFV53DFB

Models	Latch	Output 1	Output 2	Relay	V	Hz	Fail Safe	Latch	Adjustments	Trip level	Delay
KCFV53D	-	-	-	R1		X			UV:	0-20% of V nom.	0,1-30secs
KCFV53DFA	-	X	-	R2	X		X		O/V:	0-20% of V nom.	0,1-30secs
KCFV53DFB	-	X	X	R3	X	X			U/Hz:	45-65Hz	0,1-30secs
									O/Hz:	45-65Hz	0,1-30secs

Relays shown de-energised.  
R2 is fail-safe and energises when unit is powered.

KCFV53D2 - KCFV53D2FA - KCFV53D2FB

Models	Latch	Output 1	Output 2	Relay	V	Hz	Fail Safe	Latch	Adjustments	Trip level	Delay
KCFV53D2	-	-	-	R1		X			UV:	0-20% of V nom.	0,1-30secs
KCFV53D2FA	-	X	-	R2	X		X		O/V:	0-20% of V nom.	0,1-30secs
KCFV53D2FB	-	X	X	R3	X	X	X		U/Hz:	45-65Hz	0,1-30secs
									O/Hz:	45-65Hz	0,1-30secs

Relays shown de-energised.  
R2 is fail-safe and energises when unit is powered.

## Connection Diagram

### Connection Diagram without optional slave instrument

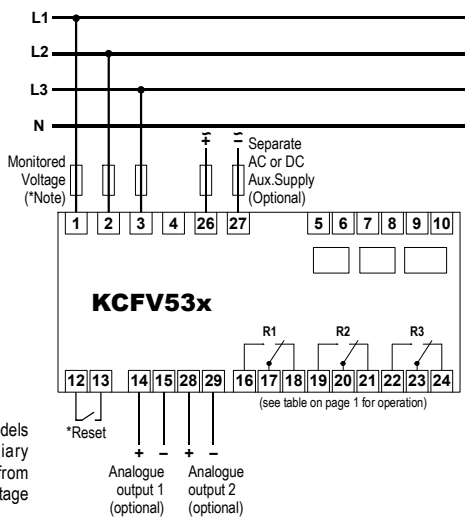

**\*Note:**  
The standard models takes the auxiliary supply voltage from the monitored voltage (terminal 1 & 2).

### Connection Diagram with optional slave instrument

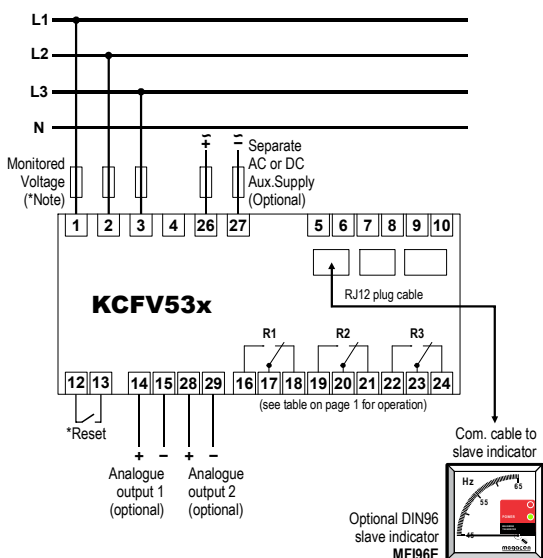

**\*Reset**  
Any latched relay is reset by linking terminals 12 and 13 or by interrupting the auxiliary voltage supply.

## Analogue Output

The output signals are proportional to the meter reading (see page 1 for an overview of models and functions).

The signal is specifically intended as an input to a control system for monitoring or control.

Add suffix from table below to type designation to specify output required:

### Outputs 1

O/P1	0 - 10mA
O/P2	0 - 20mA
O/P3	4 - 20mA
O/P4	N/A
O/P5	N/A
O/P6	N/A
O/P7	N/A
O/P8	0 - 10V
O/P9	0,2 - 10V
O/P10	4,3 - 20mA

### Outputs 2

O/P11	0 - 10mA
O/P12	0 - 20mA
O/P13	4 - 20mA
O/P14	N/A
O/P15	N/A
O/P16	N/A
O/P17	N/A
O/P18	0 - 10V
O/P19	0,2 - 10V
O/P20	4,3 - 20mA

### Relay Contacts

Burden on supply	: 170mW per relay
Switching voltage (Max)	: 400V AC, 300V DC
Switching voltage (Rated)	: 250V AC, 30V DC
Max I continuous	: 6A RMS, 6A DC
Max breaking capacity	: 1500VA AC, 18-120W DC
Dielectric strength across Open contacts	: 1000V RMS

### Connection

Terminal type	: Terminal Clamp and Screw
Wire max.	: T1-T4, T5-T10: AWG 24-14, other terminals: AWG 24-12
Screw Torque	: 0.5Nm

### Overload

Voltage	: 1.2 x Un continuous 2 x Un for 10secs
Current	: 2.5 x In continuous 5 x In for 1secs (max 25A)

## Dimensions

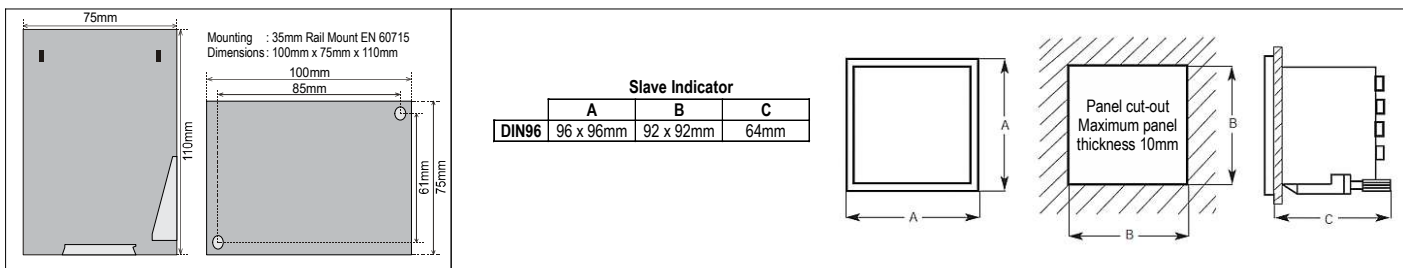

The MEGAcon policy is one of continuous improvement, consequently equipment supplied may vary in detail from this publication.

### ORDERING INFORMATION

Type	: KCFV53FB
Aux. Supply	: 200-240VAC
Input Voltage	: Nom. 230V
Range	: 45-65Hz
Analogue output 1	: O/P3: 4-20mA
Analogue output 2	: O/P18: 0-10VDC

### Optional Separate Aux. Supply:

Add **-SA** for models with Separate AC Aux. Supply. (Example: KCFV53FB-SA)  
Add **-SD** for models with Separate DC Aux. Supply. (Example: KCFV53FB-SD)

