

Model DS1200-AMT

Single Channel Dew Point Hygrometer

Ranges available between -120°C to $+20^{\circ}\text{C}$ (-166°F to $+68^{\circ}\text{F}$) dewpoint

User friendly solution for continuous on-line dewpoint measurement in dry process gases and dry compressed air, offering powerful functionality and simple interface through advanced digital technology.

Fast Response - Stable - Reliable -

Accurate - Easy to Install.

Model DS1200 from Alpha Moisture Systems is a single channel on-line hygrometer designed to measure dewpoint in process gases and dry compressed air. The panel mounted $\frac{1}{8}$ DIN dewpoint meter, providing panel protection to IP65 (NEMA4X), combines with the Model AMT range of ultra high capacitance sensors for accurate trace moisture measurement.



Measuring instrument
conforms with
BS EN 61326-1

FEATURES

- User Friendly & Advanced Functionality
- Factory set in either $^{\circ}\text{C}$ or $^{\circ}\text{F}$ Dewpoint, ppm(v), ppb(v), g/m³ or lbs/MMSCF
- 22V – 253V AC or DC Operation
- Linear 4-20mA Retransmission Signal
- 2 Independent, Fully Programmable Alarm Relays
- "AUTOCAL" CALIBRATION FEATURE
- Fast Response
- Long Term Stability
- IP66 / NEMA4 Weatherproof Protection
- Calibration traceable to National & International Standards

Combination of advanced digital technology of the display electronics and the transmitter, makes this the system of choice for a wide range of applications where precise indication, control and monitoring is critical.

Model DS1200-AMT system can be factory configured to read in $^{\circ}\text{C}$ dewpoint, $^{\circ}\text{F}$ dewpoint, ppm(v), ppb(v), g/m³ or lbs/MMSCF. The measured value is displayed on a large 4 digit, 13.8mm high, fourteen segment LED display. **Model DS1200-AMT Dewpoint Hygrometer** is fully configured to the customer's specifications.

The instrument offers two fully programmable alarm relays, which can be independently set across the full operating range. An optically isolated analogue signal, linear with the measured unit is also available (to interface with any external device).

Model DS1200-AMT can be supplied with any one of a range of dewpoint transmitters, which have all been specially manufactured to provide long term stability, so ensuring a long and trouble free service life.

The long lasting sensing element offers excellent sensitivity, repeatability and response speed - especially on dry down. Integrated electronics in each transmitter allow calibration data to be stored within its memory, making transmitters completely field interchangeable.

Each transmitter is calibrated to provide overall system accuracy of better than $\pm 2^{\circ}\text{C}$ dewpoint and supplied with a certificate traceable to international humidity standards.

Model DS1200-AMT also incorporates the invaluable "AUTOCAL" feature for easy field verification of the system response, without recourse to any additional equipment. Accidental or unauthorised operation is prevented by a simple initiation routine.

The system allows the display unit to be sited in excess of 1000m from the transmitter, connected by a simple twisted pair cable.

Specifications

MODEL DS1200-AMT Dewpoint Hygrometer

DS1200 DISPLAY INDICATOR SPECIFICATIONS

ENCLOSURE: 1/8 DIN panel mounting ABS case
DISPLAY: 4 digit, 14 segment LED indicator. Red characters 13.8mm high. Factory set to display in °C, °F, ppm(v), ppb(v), g/m³ or lbs/MMSCF
SUPPLY VOLTAGE: Universal 22Vac - 253Vac 50/60Hz & 20Vdc - 300Vdc 150mA to 15mA
POWER CONSUMPTION: 3.5W Maximum
OUTPUT SIGNAL: Linear 4 to 20mA, fully isolated. Maximum load 800Ω / 16Vdc
ISOLATION: Voltage Test / Operation - 2.3kVac / 250Vac
ALARM RELAYS: 2 independent fully programmable switched contacts. Rated 2A @ 250Vac / 1A @ 24Vdc.
ANNUNCIATORS: AL1 & AL2 LED's on front panel indicating status of each alarm
ELECTROMAGNETIC COMPATIBILITY (EMC):
 Complies with BS EN 61326-1
UL, STANDARD OF SAFETY: Certified to UL508
WEATHERPROOF CLASSIFICATION: Front panel only - IP65 (NEMA 4X).
WEIGHT: 230 grams

TRANSMITTER & GENERAL SPECIFICATIONS

SENSOR TYPE: Model AMT Dewpoint Transmitter
SENSING ELEMENT: Ultra High Capacitance - Aluminium Oxide Type
RANGES: See Step 1 below.
AUTOCAL: Field calibration / Span check facility. Activated and operated via two button switches on the Transmitter body. Locked in normal operating mode to avoid tamper.
TRANSMITTER ENCLOSURE: 316 Stainless steel body with size C, DIN EN 175301 connector.

SENSOR PROTECTION: 316 Sintered stainless steel filter - 50 micron
OPERATING PRESSURE: From 1kPa (0.01 barA) to Maximum 35,000kPa (350 barA)
SAMPLE FLOW RATE: Flow independent but ideally 2 to 5 standard litres per minute. Max: 25 litres/min
WEATHERPROOF CLASSIFICATION: IP66 / NEMA4X when Connector mated to Transmitter.
MECHANICAL CONNECTION: 3/4" UNF (16tpi) with integral Viton "O" ring seal.
WEIGHT: Transmitter and connector - 175grams
CABLE: Supplied with 2m length standard two core cable. Nominal diameter 3.4mm, 92ohms/km at 20°C
ELECTROMAGNETIC COMPATIBILITY (EMC):
 Complies with BS EN 61326-1
TEMPERATURE COEFFICIENT: Transmitter temperature compensated for operating range.
REPEATABILITY: Better than ±0.3°C dewpoint
FACTORY CALIBRATION: Supplied with Certificate of Calibration traceable to NPL / NIST
ACCURACY: ± 2°C dewpoint (NPL / NIST traceable for range -90°C to +20°C)
OPERATING TEMPERATURE: -20°C to +60°C
STORAGE TEMPERATURE: -20°C to +70°C
OPERATING HUMIDITY (External): Maximum - 95% RH Non-condensing
WARM UP TIME: 10 seconds
MECHANICAL WARRANTY: 24 months in case of faulty workmanship and defective parts.
CALIBRATION WARRANTY: 12 months (not valid if transmitter is subject to corrosives or mis-use)

How to Order - Step 1 of 3

Select from a standard range below

Model DS1200-AMT + [xxxx]

Code	Range	Resolution	Unit
RDC:	-80°C to -20°C	dewpoint	
SRC:	-110°C to -20°C	dewpoint	
GYC:	-80°C to 0°C	dewpoint	
PLC:	-100°C to 0°C	dewpoint	
SDC:	-100°C to +20°C	dewpoint	
SSRC:	-120°C to -20°C	dewpoint	
LDC:	-120°C to +20°C	dewpoint	
SHDC:	-65°C to 0°C	dewpoint	
HDC:	-65°C to +20°C	dewpoint	
resolution 0.1°C / °F			
RDF:	-112°F to -4°F	dewpoint	
SRF:	-116°F to -4°F	dewpoint	
GYF:	-112°F to +32°F	dewpoint	
PLF:	-148°F to +32°F	dewpoint	
SDF:	-148°F to +68°F	dewpoint	
SSRF:	-184°F to +68°F	dewpoint	
LDF:	-85°F to +68°F	dewpoint	
SHDF:	-85°F to +32°F	dewpoint	
HDF:	-85°F to +68°F	dewpoint	
GP:	1 to 6000	ppm(v)	resolution = 2ppm
SP:	1 to 1000	ppm(v)	resolution = 1ppm
MP:	0.1 to 100.0	ppm(v)	resolution = 0.1ppm
LP:	0.01 to 10.00	ppm(v)	resolution = 0.01ppm
PB:	1 to 1000	ppb(v)	resolution = 1ppb
HG:	0.01 to 10.00	g/m ³	resolution = 0.01g/m ³
LG:	0.001 to 1.000	g/m ³	resolution = 0.001g/m ³
LLB:	0.1 to 10.0	lbs/MMSCF	resolution = 0.01 lbs/MMSCF
SLB:	0.1 to 25.0	lbs/MMSCF	resolution = 0.01 lbs/MMSCF
HLB:	0.1 to 50.0	lbs/MMSCF	resolution = 0.01 lbs/MMSCF
VHLB:	0.1 to 300.0	lbs/MMSCF	resolution = 0.1 lbs/MMSCF

NOTE: ppm, ppb, g/m³ & lbs/MMSCF ranges are stated at atmospheric pressure. Model AMT Transmitter can be configured to provide corresponding ranges for operation at other constant pressure. This must be stated at time of order.

Order Example:- Dewpoint Transmitter Model AMT-GYC = -80°C to 0°C dp
 Model DS1200-AMT COMES COMPLETE WITH A STANDARD 2 METRE CONNECTING CABLE.

How to Order - Step 2 of 3

Select a longer cable below

CAB069-AMT + [XX]

Your AMT Transmitter comes complete with 2 metres of connecting cable as standard.

To order a longer length in metres, add number after this part number.

Example: CAB069-AMT-10 for 10 metres

Non-Standard off the shelf cables available in 3, 4, 5, 10, 12, 15, 25m lengths. For longer lengths please call.

AMT Standard Cable 2 Meters



Part No. CAB069-AMT

How to Order - Step 3 of 3

Select a transmitter holder below

Comes complete with mounting plate.

2 grades available: 303 or 316 Stainless Steel

ADSH-AMT 303 + [X] [X]
 ADSH-AMT 316 + [X] [X]

X = Choose INLET Pipe Fitting
 0 = None 1/8" NPT Port
 4 = 1/4" - Pipe OD
 8 = 1/8" - Pipe OD
 6 = 6mm - Pipe OD

X = Choose OUTLET Pipe Fitting
 0 = None 1/8" NPT Port
 4 = 1/4" - Pipe OD
 8 = 1/8" - Pipe OD
 6 = 6mm - Pipe OD

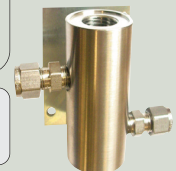

Order Example:- For Transmitter Holder 303 grade with 2 x 1/4 fittings Order ADSH-AMT 303 - 4 - 4

Dimensions

Model AMT Dewpoint Transmitter

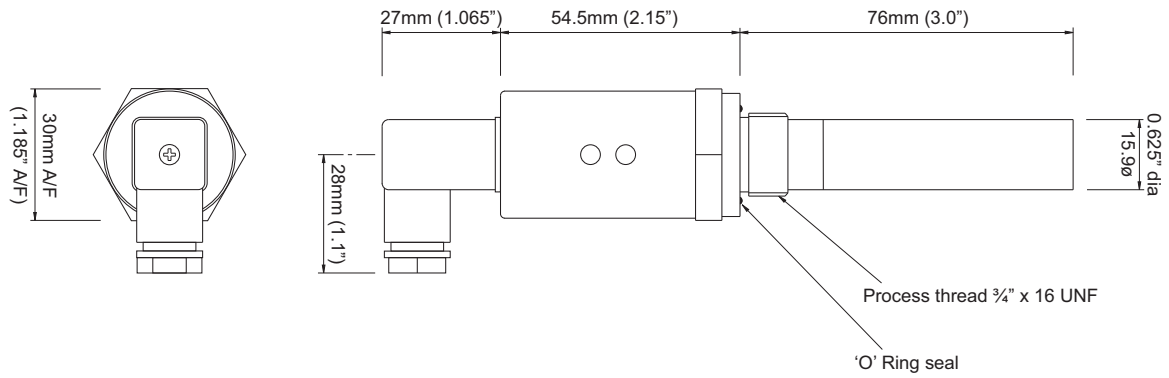

Model ADSH-AMT Transmitter Holder Flow Through Sample Cell

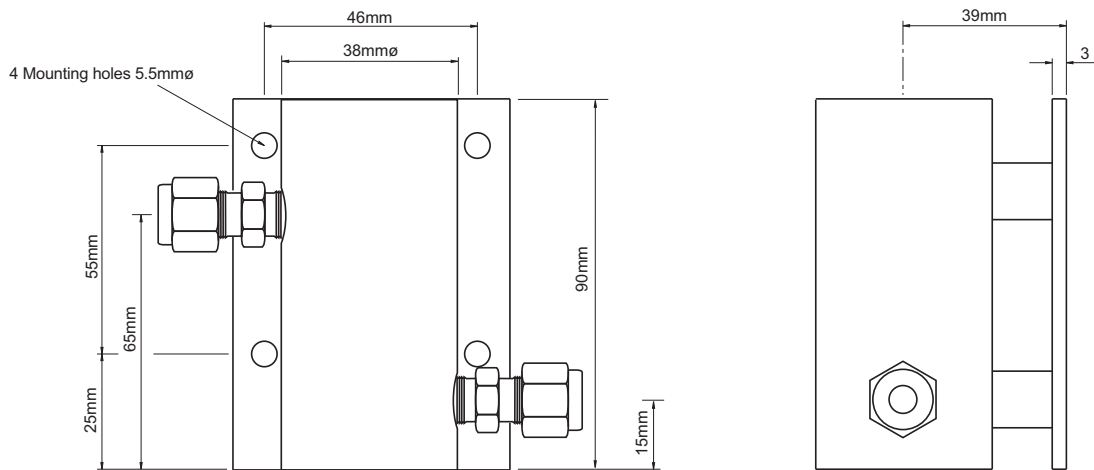

Note: The Assembly is shown with 1/4" OD tube fittings. The dimensions across the tube fittings will vary for all other size fittings.

Model DS1200 Display

Stable, Accurate and Reliable Alarmed Monitor

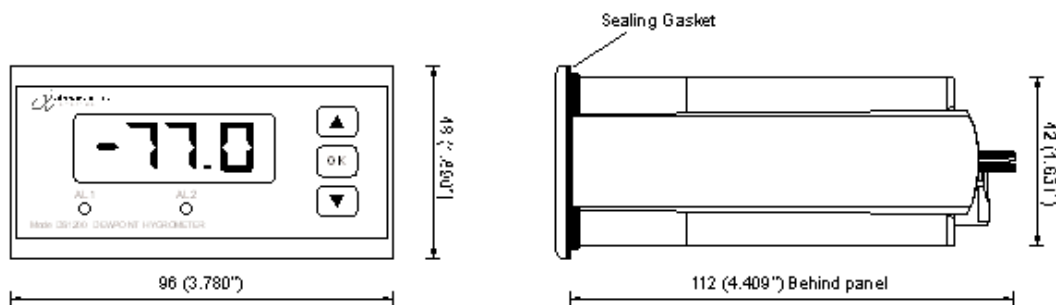

Panel out-out: 44.5 x 91.5 (1.752" x 3.602")

Maximum panel thickness: 10mm (0.394")

Application Wiring Diagrams

Model DS1200 Display Connection Details

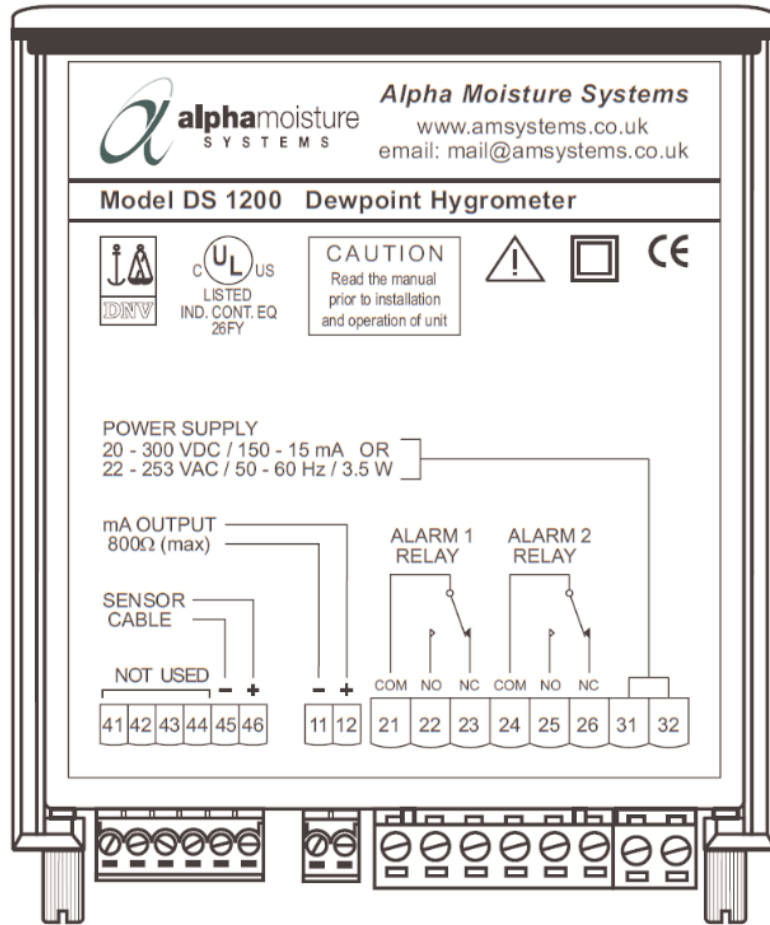

Note: The Model AMT is not suitable for Ammonia (NH_3), Chlorine (Cl) - (See Model EDM data sheets) and Hydrogen Chloride (HCl). SF_6 can be monitored with no effect to the sensor element. Sulphur Dioxide (SO_2) can be monitored if the moisture content is low, less than 100ppm(v).

Distributor Information

Product specification may be subject to change, without prior notice, as part of our ongoing product development programme.

2144 Model DS1200-AMT pd220416- Iss-2



Alpha Moisture Systems Limited. Registered Office: Alpha House, 96 City Road, Bradford, BD8 8ES
 Registered in England and Wales No. 3902302 - VAT Registration No. GB 607 2075 63 - WEEE Producer Registration No. WEEE/EA0067TX

© Alpha Moisture Systems Ltd.

Tel	+44 (0) 1274 733100
Fax	+44 (0) 1274 733200
Email	info@amsystems.co.uk
Website	www.amsystems.co.uk